

Service Guide

Digital Cycling Unit (DCU)



The information contained in this document is intended for basic instruction on installing and servicing a Comverge DCU. Unqualified persons should not attempt to service the unit. Comverge is not responsible or liable for any damage or injuries, physical or otherwise, sustained while servicing or installing one of these units. Any such liability lies solely with the installer.

Comverge, Inc.
120 Eagle Rock Ave., Suite 190
East Hanover, NJ 07936

What is a DCU?

A Digital Cycling Unit (DCU) is a device installed at the home to control air conditioning units during a peak load period (as explained on page 3). The DCU receives radio signals from Utility and then begins to cycle the appliance.

The device incorporates a circuit board, RF paging receiver, and transformer enclosed in a water-tight injection molded, high-impact poly-carbonate box and is usually installed near the air conditioner compressor. This device functions with central air conditioning systems and is not designed for window-style or small space units.

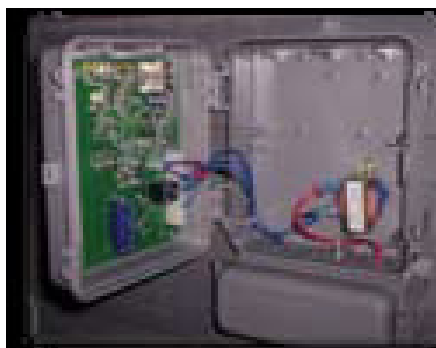
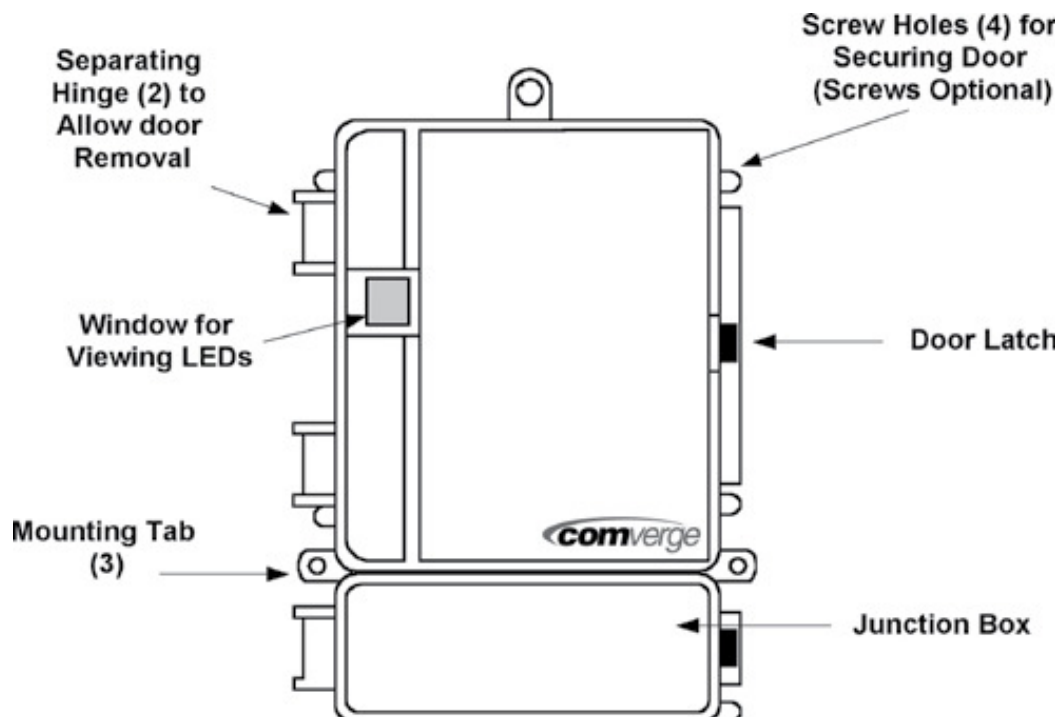

Environmental: Temperature: -30 to 60° C,

Humidity: 0 percent to 95 percent (non-condensing)

Electrical: Input 120, 240, 120/208/240, 240/480 VAC

Packaging: Injection molded, high-impact poly-carbonate

Communications: 40 dB image rejection ; 50 dB min selectivity; 139 to 174 MHz range; Greater than 20 $\mu\text{v}/\text{m}$ RF sensitivity (internal antenna); Greater than 10 $\mu\text{v}/\text{m}$ RF sensitivity (external antenna)

Regulatory: FCC part 15; ANSI C70-37; UL Listed

What does the DCU do? How does it work?

The DCU responds to radio signals issued via an RF paging network – a network that communicates much like a cellular network. When the utility sees a system peak load approaching or when a system emergency occurs, it issues a signal over this network that tells the DCU to begin cycling participating units. Unlike some devices designed to completely turn the air conditioner off, Comverge’s DCU intelligently cycles the unit based on utility’s need so that the home remains cool while still reducing electrical demand.

When the peak demand period ends, Utility will issue another signal that tells the units to gradually come back on line – one at a time in a random order – helping a utility to maintain safe and reliable service throughout a peak period. This gradual ramp-up function, called “cold load pickup” is pre-programmed into the unit and may activate whenever power is interrupted for more than 20 seconds. This may delay the units’ ramp-up by anywhere from 0 to 30 minutes.

How can I explain the DCU to a homeowner?

A DCU is a device that, when connected to your outdoor central air conditioning unit, optimizes the distribution of electrical power to homes and businesses during peak demand periods. During activation, a wireless signal is issued that briefly reduces the A/C condenser’s run-time. The A/C system remains operational at all times, so the fan will continue to circulate indoor air through the home. This lessens the strain on the power grid during periods of peak demand.

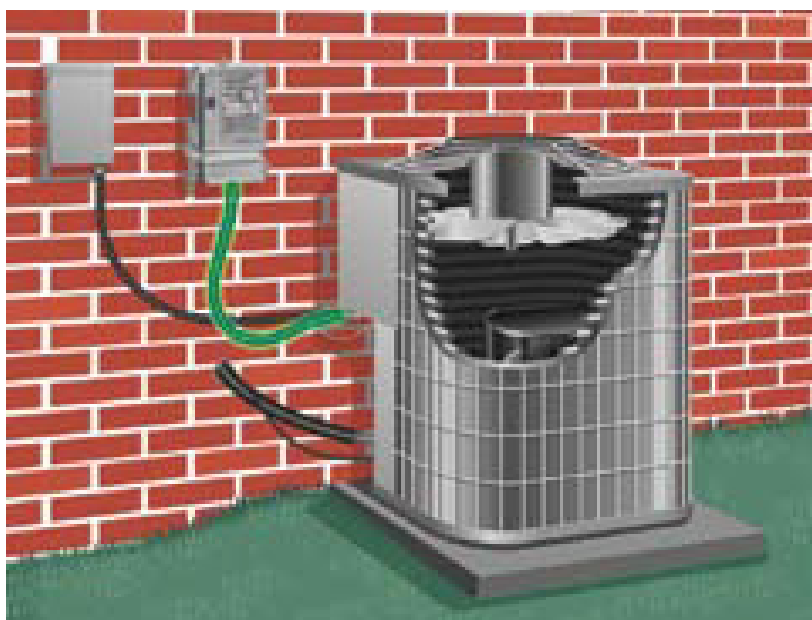

Figure 1: *Traditional Installation Method*
– DCU connected to A/C unit

Installing the DCU

Due to the variety of installation configurations, general instructions are provided. Comverge does not take responsibility and is not liable for improper installation or servicing. If the installer does not understand how to install or service the device, he or she should contact Comverge for instructions before touching the DCU.

1. Circuit identification

Turn the appliance off at the disconnect panel. Confirm that the circuit is properly marked and that power to the appliance is off. If necessary, correctly label the customer's breaker/fuse that controls the appliance.

2. Mounting the DCU

While most units will be mounted on the house, some may be mounted directly on the air conditioner or heat pump condenser enclosure. A junction box at the bottom allows for connection to any external wiring required. Note: the DCU must be mounted vertically in order to receive the best signal reception. While it is not necessary to ground the DCU due to its nonmetallic enclosure, local electrical codes must be checked to determine grounding requirements for any fittings, junction boxes, or conduits that are to be attached to the DCU. Stainless steel screws should be used in each of the three mounting tabs to ensure a clean and sturdy installation.

3. Wiring instructions

All 240 volt cables shall be in flexible conduit with appropriate fittings on each end of the conduit. All cables must be installed in a manner that maintains the DCUs watertight integrity. Connect power to the red and black leads in the unit. This must comply with the voltage information indicated on the front label of the unit. Splice the DCU into low voltage thermostat circuit by cutting the thermostat wires and utilizing the two blue leads in the DCU to connect it in series with the thermostat. Note: Wire colors may vary, depending on model chosen. Exterior label will specify coloration for each unit.



Figure 2: *Traditional installation shows DCU wires (bright red, black, and blue) installed at compressor.*

Servicing Units Connected to the DCU

Due to the variety of installation configurations, general instructions are provided. Comverge does not take responsibility and is not liable for improper installation or servicing. If the installer does not understand how to install or service the device, he or she should contact Comverge for instructions before touching the DCU.

Servicing the air conditioner or heat pump

The installation of a DCU DOES NOT complicate the servicing of an air conditioner or heat pump. HVAC units function normally when the DCU relay is in its closed position. A red LED will appear in the window of the switch when a control event is occurring. If no LED is illuminated, the DCU is in its closed position.

If the Red LED in the window is lighted, then the relay is open and the condenser will not run normally. If this is the case, open the control panel of the condenser and find the wires attached to the compressor contactor. Place a jumper wire between the two blue wires. This action will bypass the relay to the DCU. This procedure will allow you to service the unit as if the switch was not there. After service on the unit is complete, remove the jumper. This will restore the DCU to normal service.

Tampering with or disabling the unit is prohibited by agreement. The unit will indicate if it has been tampered with.

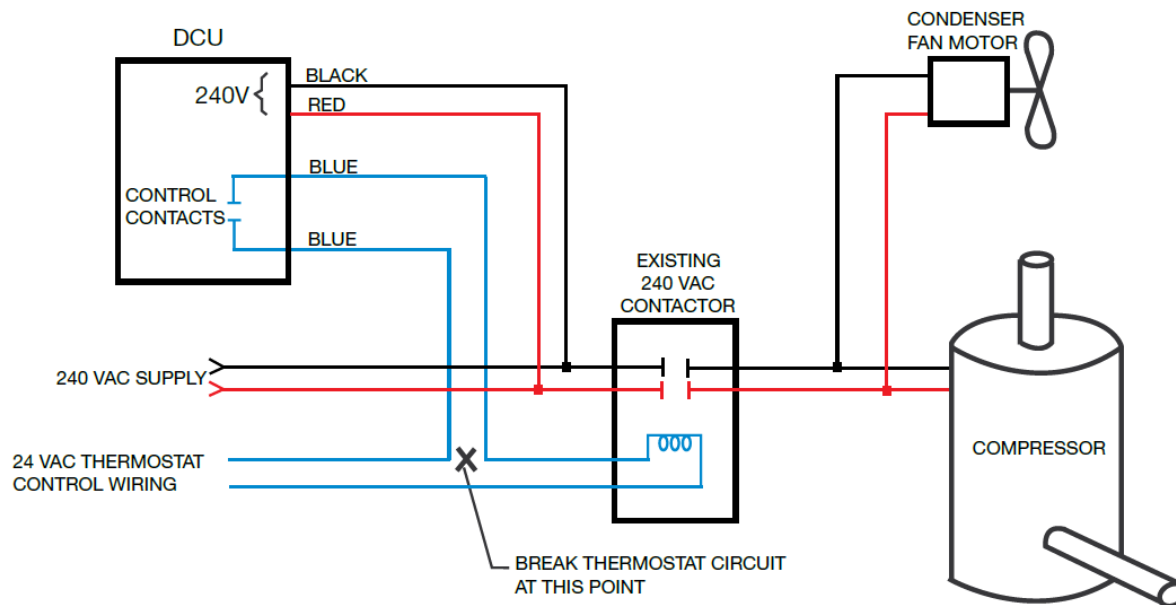

Figure 3: DCU Wiring Diagram

Troubleshooting/FAQs

How do I bypass the DCU for troubleshooting?

The installation of a DCU DOES NOT complicate servicing of an air conditioner or heat pump. The normally closed relay shown in the wiring diagram on the previous page will allow the compressor to run as if the DCU were not installed.

When a radio signal is issued, the DCU will go into cycling mode and a red LED will appear in the window of the unit. If the LED is not illuminated, the relay inside the switch is closed, so the compressor will operate normally.

If the Red LED in the window is illuminated, then the relay is open and the condenser will not run normally. If this is the case, open the control panel of the condenser and find the wires attached to the compressor contactor. Place a jumper wire between the two blue wires. The jumper bypasses and completely disables the DCU. This will allow you to service the unit as if the DCU was not there. After service on the unit is complete, the jumper must be removed. This will put the DCU back in service.

How does the DCU affect the wear on the compressor contactor?

The compressor contactor (shown in the drawing as the EXISTING 240 VAC CONTACTOR) is the device that connects the 240 volt supply to the compressor to cause it to start. The thermostat

controls the compressor contactor by putting 24 volts on the coil of the contactor. When the thermostat detects the need for cooling, it connects 24 volts to the relay coil of the compressor contactor, causing the relay to close its contacts. Compressor contactors are simply relays that have been adapted for this purpose.

As a relay, it is rated for the maximum number of operations (contact closures and openings) that it might have to execute during its lifetime. Most compressor contactors are rated for at least 100,000 operations. Over the twenty-year life of the compressor, the DCU may increase the number of compressor contactor closures / openings by approximately 1,600 or an additional 1.6 percent.

How does the DCU keep from short cycling the compressor?

The minimum time off for the DCU is 7.5 minutes. This exceeds all manufacturers' recommendations and ARI standards of a minimum of 5 minutes. The 7.5 minutes will allow the pressure in both lines to equalize before the unit is started again.

What happens if the electronics in the DCU fail?

As shown in the wiring diagram above, the DCU has a normally closed relay that is wired in series with the thermostat. If the electronics fail, the relay will return to its closed position and the air conditioning unit will operate normally.